

## Norma Sturges' Butt Method #2

### AKA: Easiest Butt Method Ever for Outer Rows of a Braided Rug

This method differs from Sturges' first method, demonstrated in February, in that all the seams are found on the inside, folded edges of the braid. The inside location for all seams makes it appropriate for the outside row of a rug or chair pad.

Sturges recommends that this butt method is done on the rug, meaning that most of the row has been laced onto the rug, leaving 6 inches at the Start and Finish free for butting. However, this method can be performed either on or off the rug.

#### A. Braiding the Row

1. Fold each strand as for braiding and place on a Start Pin.
2. Braid enough length for the row plus about 6 inches of overlap at the Start. Clamp end with clothespin.

#### B. Optional Lacing

1. If desired, lace the braid onto the chair pad, leaving 6 inches free at the Start, and the same 6" free at the Finish.

#### C. Arrange the Braid for Butting

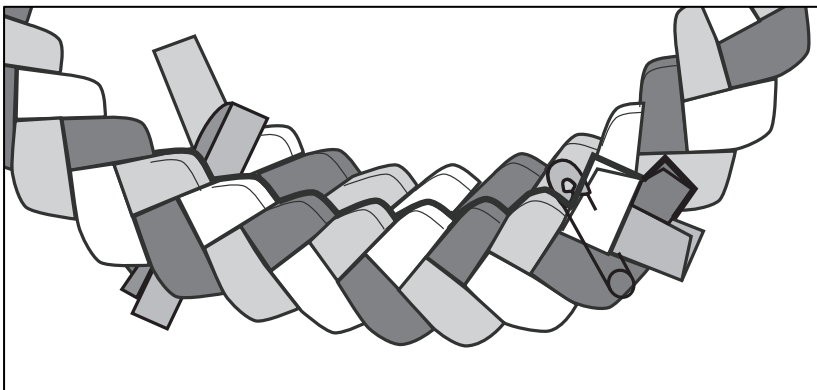

1. Front of the braid is facing up.
2. Folded-edges are away from you, or turned toward the center of the rug.
3. Start braid in front of and closer to you; Finish braid with clothespin is in back and further away from you. The braids should overlap by about 3 to 4 inches.
4. Colors of braid are matching up at butt site.

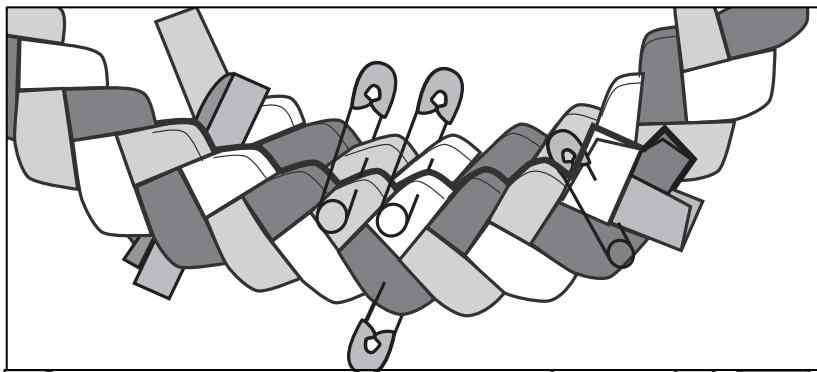

#### C. Pin the Matching Loops Together with 3 Pins

1. Pin the matching Start and Finish loops together at the Butt Site. Pin two sets on the folded-edges side, and one set on the smooth-side of the braid.
2. In picking the triangular set of 3 loops, make sure the smooth-side set is found *between* the folded-edges side pairs. Also, make sure there is at least one free set between the pinned loops and the Start Pin (diagram shows 2 sets free between pinned loops and Start Pin).

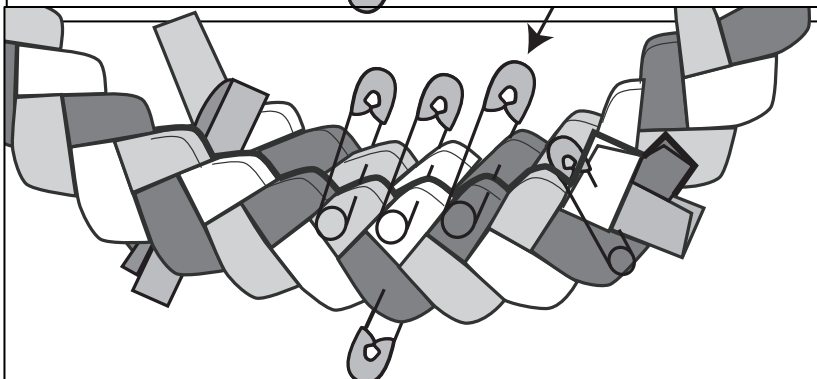

#### D. Place a Pin to the Right

1. Place another pin to the right of the two on the folded-edges side (see arrow). Its color should match the single set of pinned loops on the smooth-edge.

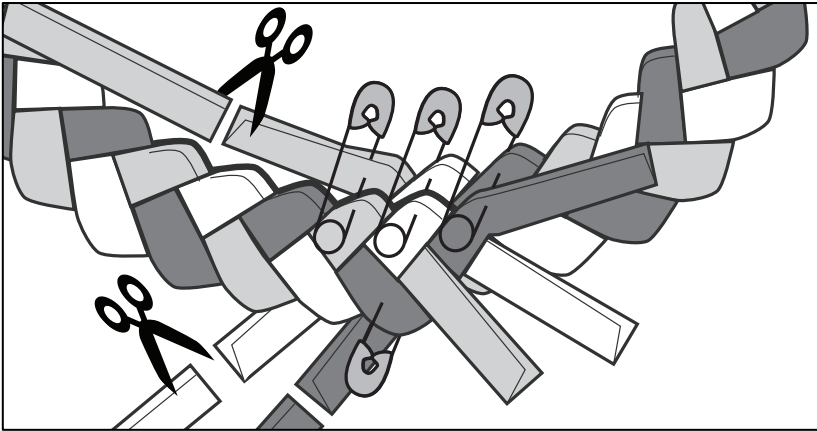

#### D. Take off Pins and Unbraid

1. Take off the Start Pin.
2. Take off the Clothespin from the Finish.
3. Unbraid back to the 4 set pins.
4. Trim all strands to 2" beyond the pins.

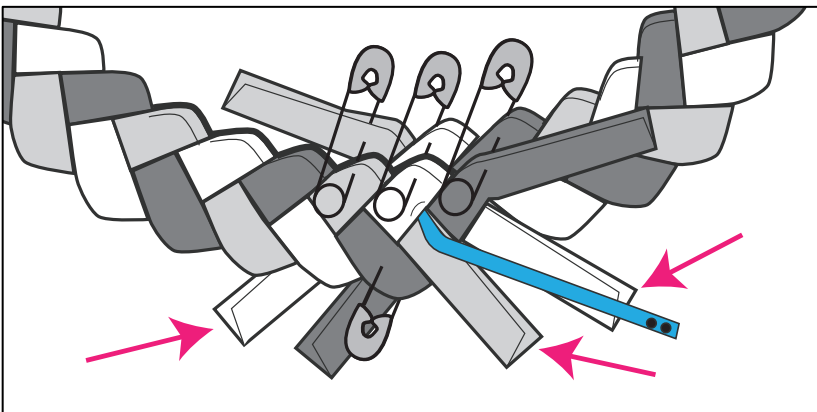

#### E. Free Both Ends of the Left and Middle Set

1. Use a braidkin (shown in blue) or your fingernails to free the ends of the left and middle set of strands.
2. The 3 strands that are contained within the braid and need to be freed are shown with pink arrows.
3. The strands of the left and middle sets should end up in two X's on the folded-edges side of the braid.

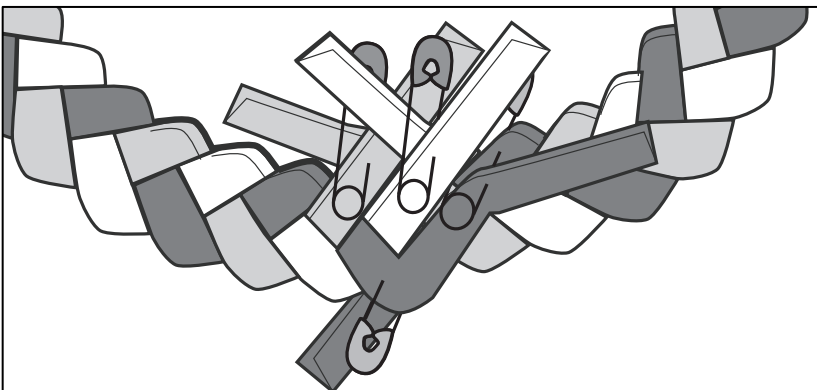

#### F. What the braid will look like after the Left and Middle Sets' Ends are Freed

1. The left and middle pinned sets now have their ends arranged in X's, with the strands coming from the left braid (Start) in front of the strands coming from the right.

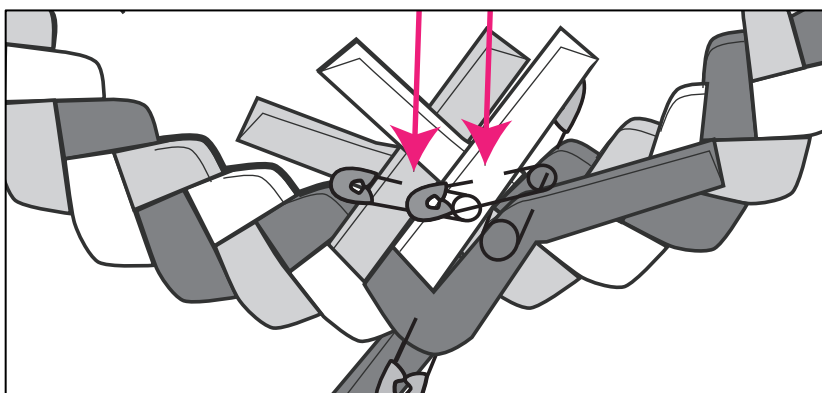

*G. Re-Pin Left and Middle Sets  
Firmly along Side of Braid*

1. Working with one set at a time, and holding firmly onto the center of the braid to keep all strands in place, un-pin and re-pin each set firmly along the side of the braid.
2. Arrows show the sets re-pinned firmly.

**Comment:** So far this butt technique has been very similar to the Sturges Method #1, with only a few minor variations. Next comes the part that really differs from the first method, because the third set of strands requires *re-weaving one strand* from the front, Start braid *into* the back, Finish braid.

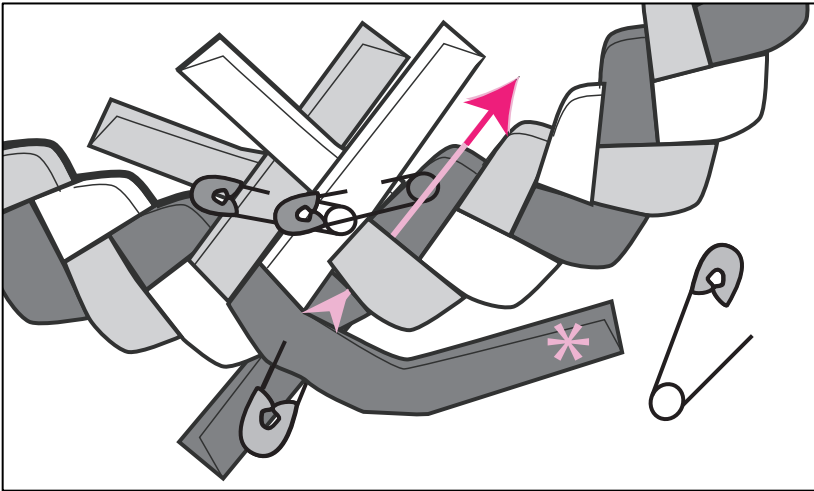

#### H. Third Set, on Right

1. Un-pin the folded-edges side pin of the set on the right. Keep the pin nearby, because it will be used again soon.

2. Weave the end of the front strand (pink asterisk) along the path of the back strand, under a loop as shown.

(I use a hemostat for this to drag the strand upward under a loop, but you can also just use your fingers).

3. Re-pin the 3<sup>rd</sup> set together on the folded-edges side of the braid.

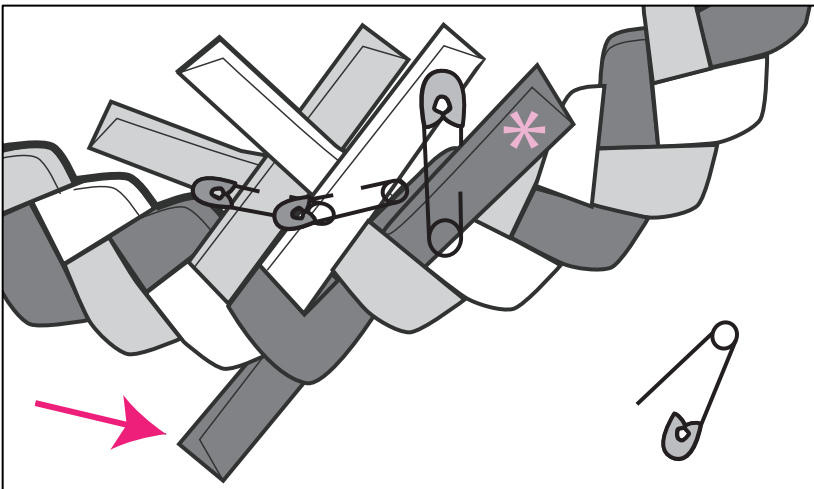

#### I. Re-Pinned Third Set, and Freeing Its Ends

1. The third set has been pinned together on the folded edges side.

2. Remove the Safety Pin from the smooth-side of the braid.

3. Arrow points to the end that is still contained within the braid.

4. Pull the contained strand out of the braid so that the ends form an X on the folded-edges side.

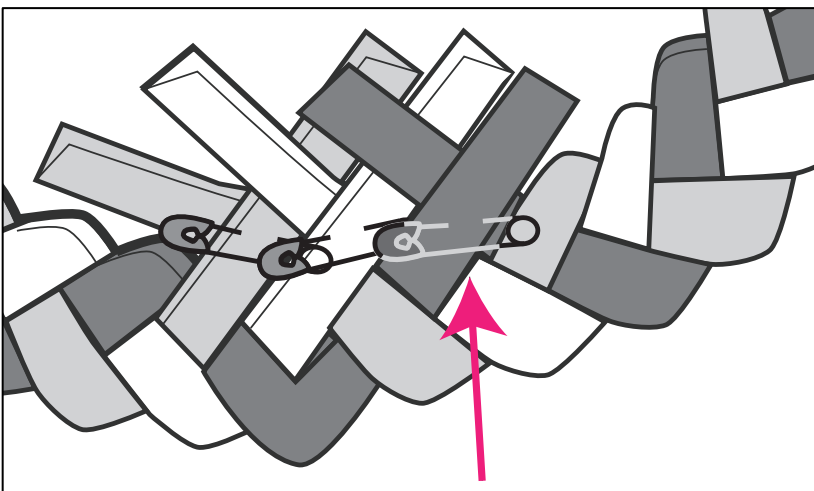

#### J. Third Set Pinned along Folded-Edges of Braid Firmly

1. Arrow points to the third set, which has its strands arranged in an X.

2. The third set has has been re-pinned firmly along the folded-edges side of the braid.

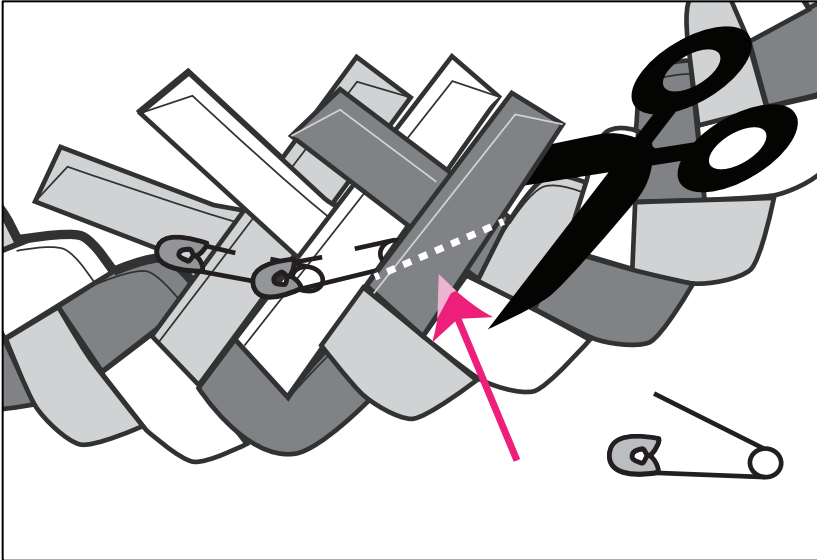

### K. Cut and Sew the Folded-Edges Sets, One at a Time

1. It doesn't matter which set you start with. I'm showing the third set but you could start with any of them.
2. Thread a needle with thread to match the set, and knot the ends, so that it is ready for stitching.
3. Grasp the braid in its center firmly so that both strands about to be cut are under your control.
4. Carefully unpin the set and cut both ends close to the braid. Keep a firm hold on the braid so that the ends don't move from position. Arrow indicates the cut line.

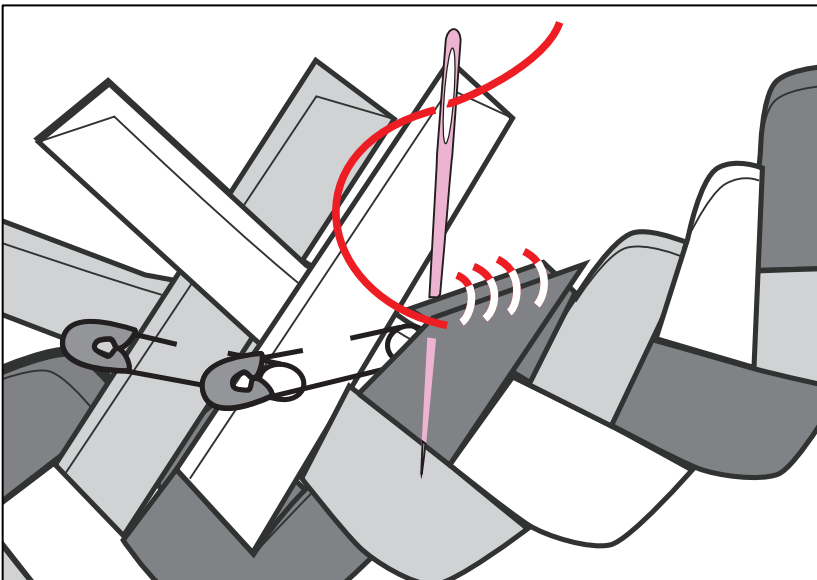

### L. Sew the Cut Edges

1. Overcast the cut ends with matching thread. The stitches will be hidden on the side of the braid.

### M. Repeat for Remaining Two Sets

1. Repeat steps K and L for the remaining sets of strands.
2. Lace the braid onto the rug! Done!