



## Snowflake Trivet – Left Opening

December 18, 2022

Instructor: Christine Manges

---

The Snowflake Trivet is a fun and quick gift to make for the holidays!

The Snowflake Border was first presented in the 2011 book by Kris McDermet, Christine Manges, and Dianne Tobias: Combining Rug Hooking and Braiding: Basics, Borders, and Beyond. The border naturally curves, so it is most suited to placing on rounded shapes. It looks complex, but it's a simple repeating pattern in only one row, so it's much easier than it looks!

The Snowflake Trivet above was made by Karen Levendusky.

I think the easiest method for butting the border row is the Enclosed End Butt.

### Supplies

- Usual braiding supplies: scissors, needle and thread to match fabrics, hemostat, lacing needle and lacing cord, clothespin, a bunch of safety pins.
- A round braided center with 36 loops in the last row, if butted; if continuously braided, make the outside row taper to complete Row 4.

### Begin Braiding the Snowflake Border

1. Make Enclosed Ends for each of the 3 strands.

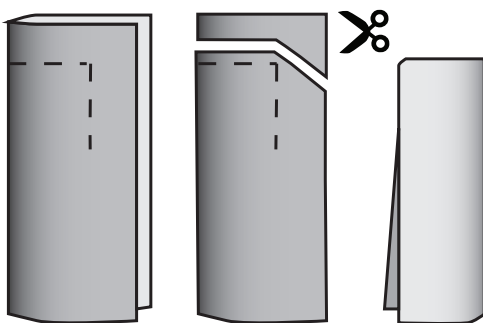

**Left** – Fold strip end lengthwise, right sides together. Starting at fold, and  $\frac{1}{4}$ " down from edge, stitch  $\frac{2}{3}$  of the way across the folded strip, then drop the needle, turn, and stitch downward.

**Middle** – Trim corner and end. DO NOT trim along side.

**Right** -- Turn right side out. Push the corners out, so that the end is straight across.

## 2. Arrange the strands on the Start Pin.

Place the three strands on the Start Pin, with the right strand  $\frac{3}{8}$  longer than the other two strands. Keep all folded edges left.

Note: the diagram shows strands of three different values, but this difference is not necessary. All three strands can be the same color if desired.

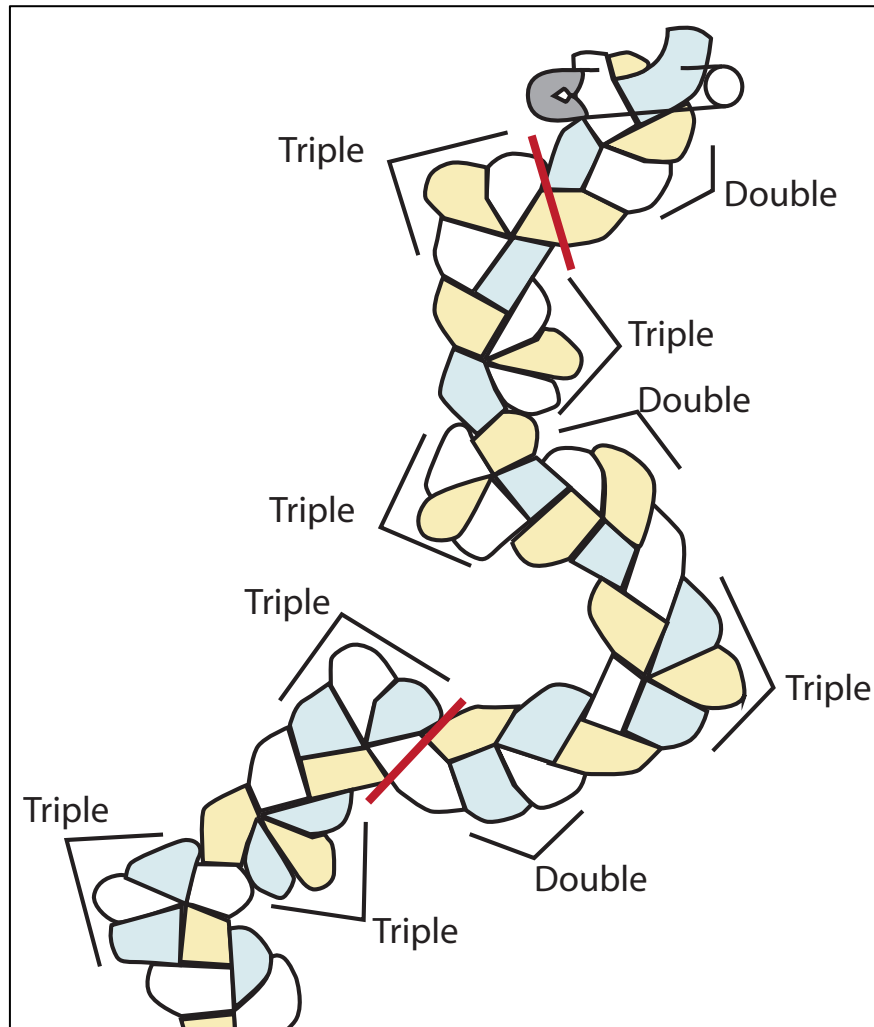
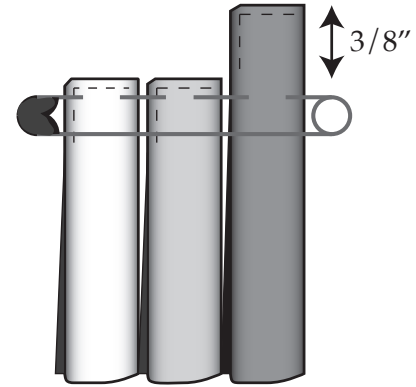

Note: red lines in diagram represent the repeat between \*\* above.

## 5. Lacing on the Border

Take 6 safety pins and space them evenly around your center, every 6 loops.

If your outer row has a taper, then space the pins every 6 loops on the non-tapered portion, and eye-ball where to space the pins in the taper.

## 3. Begin Braiding

Diagram left shows beginning braiding the Snowflake Border.

a. (Begin Braiding with the long strand on the Start Pin).

There are double corners and triple corners.

(RR,L) = right, right, left  
(LLL,R) = left, left, left, right

**Braid:** Right, left,  
(RR,L), right,  
\*\*(LLL,R), left,  
(RRR,L), right,  
(LLL,R), left,  
(RR,L), right, left  
(RRR,L), right, left  
(RR,L), right\*\*

Repeat between \*\* until there are 6 large outer points and the braid overlaps the Start Pin by about 2 more inches of braid.

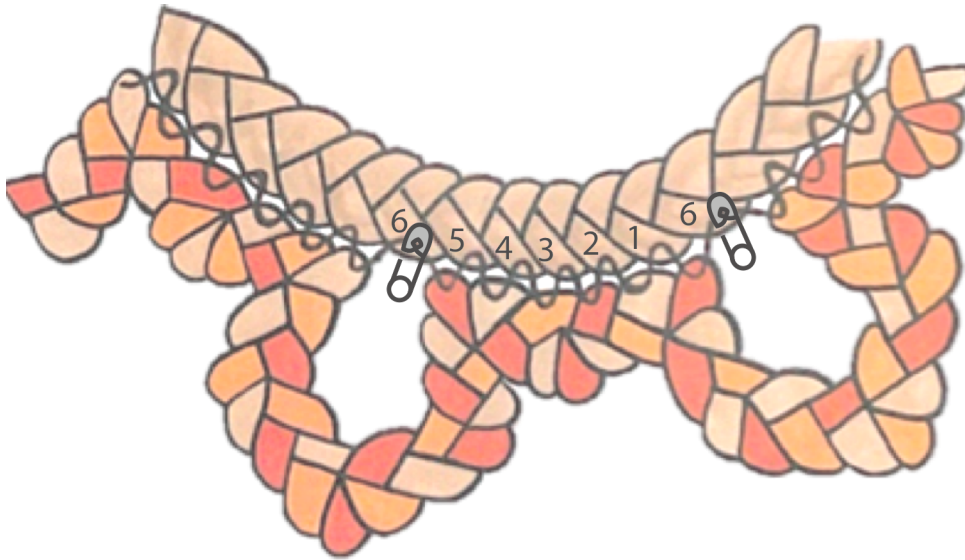

Diagram left shows lacing on the border. Note that the safety-pinned loops are the ones between inside triple corners on the border.

Begin lacing with the first inside triple corner after the large outer point. Lace the middle

loop of the triple, then a rug loop, then the 3<sup>rd</sup> loop of that triple, then a rug loop, then the next loop just before an outside triple, then a rug loop, then lace the crossover loop after the triple (this is the loop to skip if you have a 5-loop segment) then continue alternating as before.

Finish lacing with the middle loop of the inside triple just before the next large outer point, then the safety-pinned loop.

**Q: Why lace the crossover loop?**

**A.** Because it seemed to look best when it was laced. If you are having trouble hiding your lacing thread, then DON'T lace it and instead go through 2 rug loops in a row (#3 & #4) before proceeding to lace the loop after the crossover.

6. Butting the Border: Enclosed End Butt

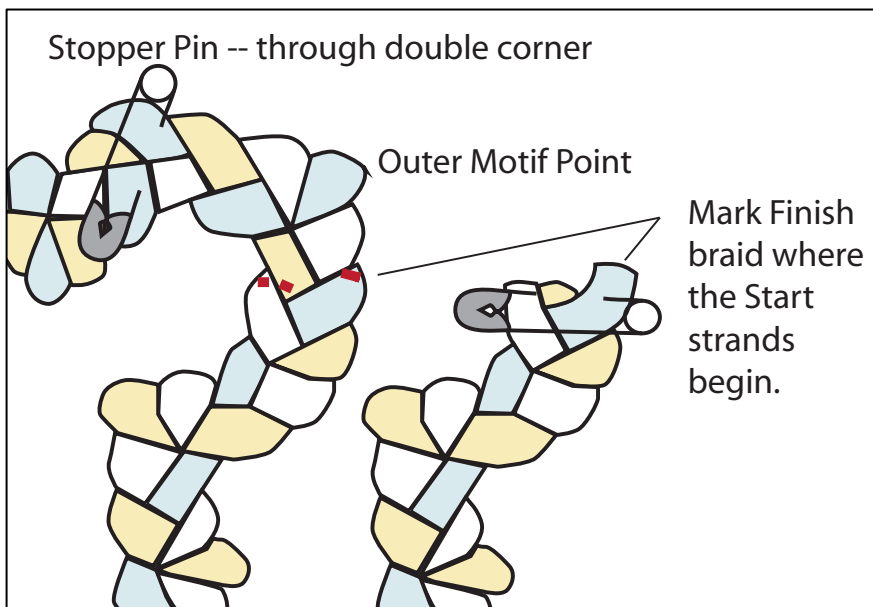

a. Match up Start and Finish, and Mark for Butting

Lay the Finish down, then the Start on top of it. Match up the corners and the colors. Diagram left shows the Finish braid on the left, and the Start braid on the right.

On the Finish Braid, use small safety pins to mark where there are red dashes:

1. The bottom of the crossover loop of the large outer point's triple corner.
2. The next loop braided on the right after the crossover loop: pin in the upper outer point of this loop.
3. The next loop braided on the left after the crossover loop: pin in the upper outer point of this loop.

TAKE A PHOTO of your pinned strands.

b. Referring to above diagram, place a Stopper Pin through the 2<sup>nd</sup> loop of the double corner before the Outer Motif Point. Stab deep into the braid, and come up in the same-color loop just before the double corner. Be sure to catch all three strands in the Stopper Pin.

- c. Unbraid back to Stopper Pin.
- d. Cut each strand  $\frac{1}{4}$ " below marker Safety Pins.
- e. Make Enclosed Ends, just as you did for the Start.
- f. Trim, and turn right-side-out. Push out corners.
- g. Re-braid tightly: Left (crossover loop of DC), right, left, (RRR,L), right, left. (Be sure to braid that final "left").
- h. Put a large Finish Pin across all 3 strands. Refer to your photo, checking that your colors are in the correct order at the Finish.

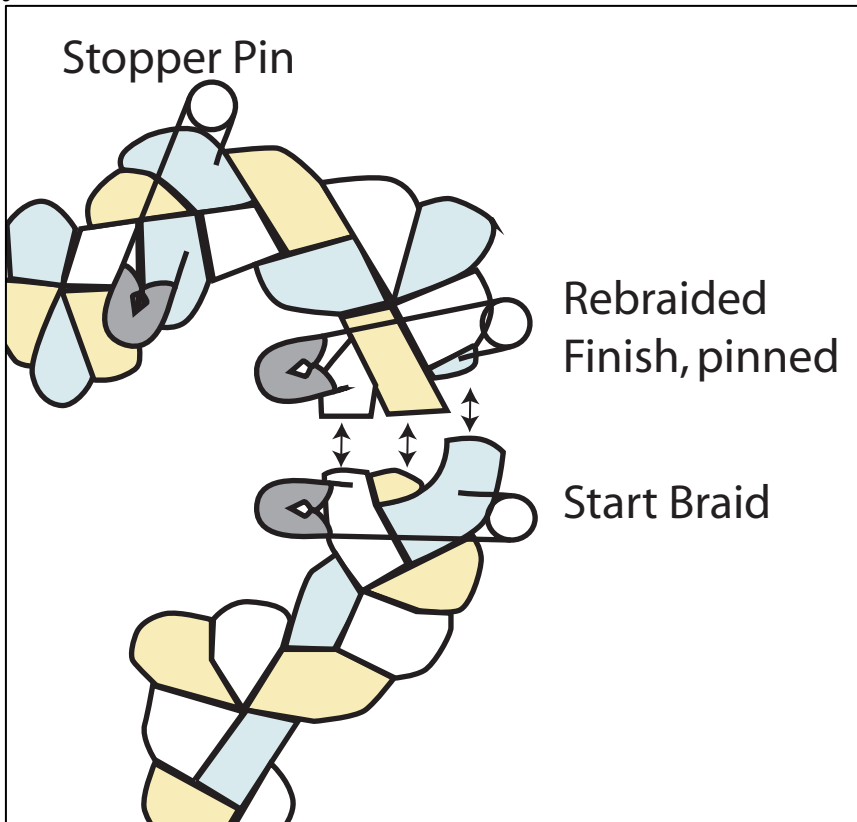

The Finish's CROSSOVER LOOP of the outer point's triple corner matches up with the MIDDLE strand at the Start.

The SHORT LOOP ON THE RIGHT of the Finish matches up with the LONG RIGHT loop at the Start.

The next loop braided on the LEFT AFTER THE CROSSOVER matches up with the LEFT LOOP on the Start.

- i. Place safety pins linking the sets of loops, and then remove the large Start Pin and the large Finish Pin.

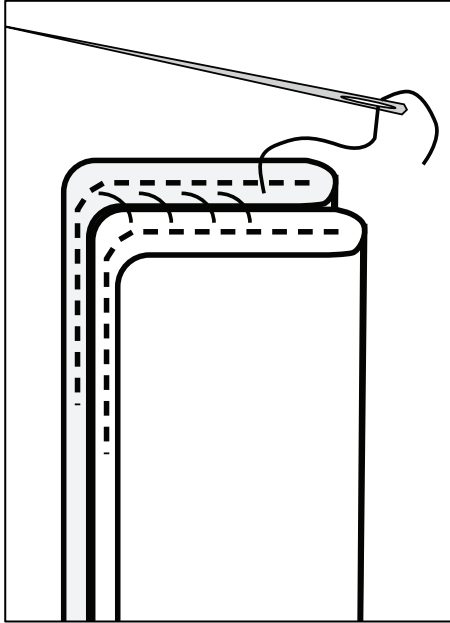
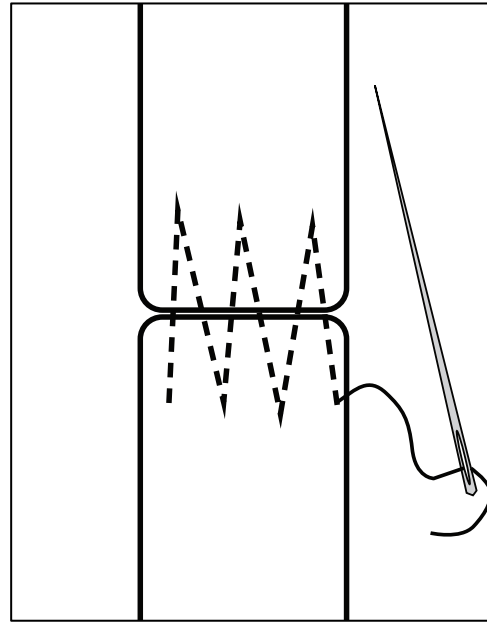
**Stitch backs together****Stitch fronts together**

**j.** Working with one set at a time, pull on the ends to get some length to work with. Arrange the ends so that they are back-to-back, with folded edges left.

**k.** Thread a needle with matching thread. Bury the knot inside the corner of one strand, and stitch the backs together where they are visible.

**l.** Straighten out the ends so that the fronts are flat. Use diagonal stitches to unite the fronts, entering the fabric for each stitch close to where the thread came out of the last stitch, and with most of the thread path buried. Be sure to stitch the sides and corners!