

Triangle Butt over 3 Braid Loops

Instructor: Christine Manges

The triangle butt has a bunch of different variations. Some triangle butts weave a Finish strand into the Start braid, some weave a Start strand into a Finish braid, and some do not do any weaving at all.

Supplies

- Start Safety Pin
- Finish Clothespin
- Scissors w/ blunt tips
- 3 large safety pins
- Hemostat
- Black & silver Sharpie markers
- Needle & thread, or sewing machine

The butt as shown here is one of the simplest. It involves weaving one strand from the Start of the braid into the Finish. It is performed over 3 counted loops of straight braid. While this butt won't work everywhere, it will work in most places.

This butt is performed "on the rug" – in which the braid is already laced onto the rug, and has just a portion of loops unlaced near the butt site. About 6 or 7 loops unlaced at the Start and Finish of the braid should be enough. I recommend doing a butt over a curved region of a rug, so that any extra fullness can be eased in with extra skips/increases as needed.

This butt is also performed "off the rug" – in which the braid is not laced on. Usually when butting off the rug, one is following a pattern that specifies a number of loops per row. When butting at a specific loop count, start counting the braid loops with "Zero" and finish counting on the specified number, then pin zero and that loop together.

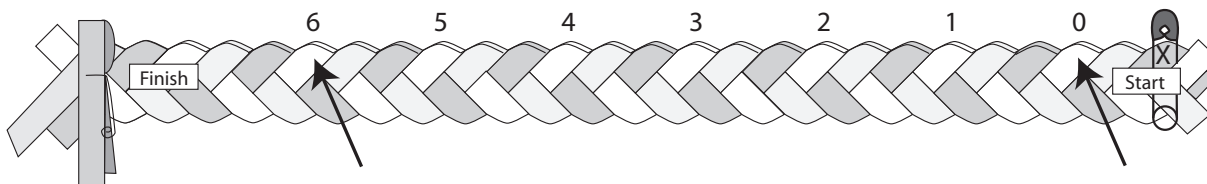

Diagrammed Example: the pattern calls for a loop count of 18, or a "set" count of 6 (a set is the 3 loops along one side of the braid). Starting with zero, count same-colored loops to 6, then pin 0 and 6 together. Remember to braid 5-6 more loops for some overlap at the Butt site.

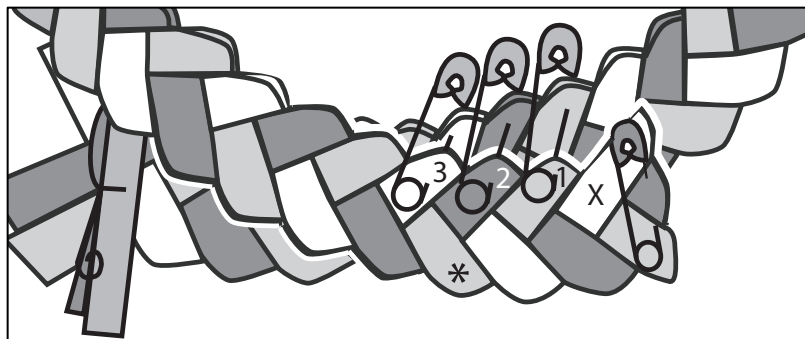

Arrange the Start and Finish as follows

- The fronts of the braids are showing
- Open folded edges face up & inward toward the center
- Start Braid has a safety pin
- Finish Braid has a clothespin

- Start braid is in front and the Finish braid is in back
- There are at least 3 loops overlapping on the Start and Finish
- The "x" in the diagram above indicates the messy loop in the Start Pin – I generally recommend omitting the loops in Start Pin from the 3 loops chosen for the butt.
- The asterisk indicates the strand that will be woven from the Start Braid into the Finish braid.

Where to Place the Butt Site:

Different teachers will give you different recommendations. Some recommend butting along straight sides; some recommend butting along a curve.

I recommend butting on a curve. Why? Because if the loop colors don't match up properly at the butt site, it is ALWAYS better to loosen the braid than pull the braid tight to make loop colors match. Loosening the braid gives you extra loops to lace into the rug. Unlace as far as needed to ease in an extra skip or two near the butt site. These extra increases are more easily hidden on a curve than on a straight portion of braid.

Instructions for the 3-Loop Butt:

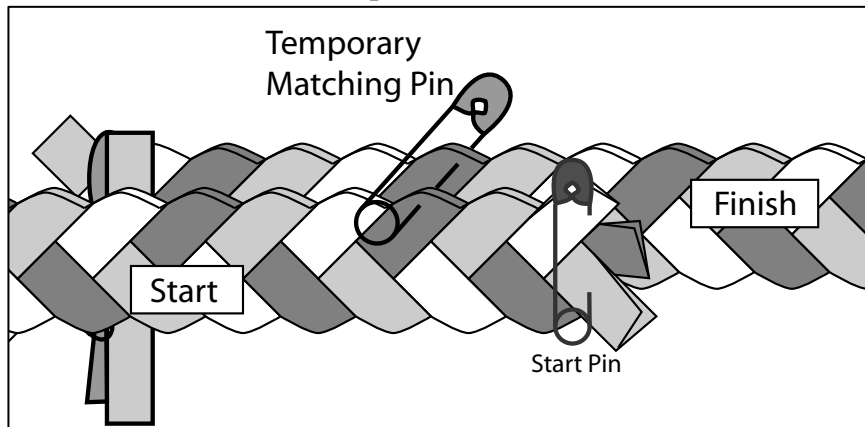

1. Once you have aligned the loops and chosen your butt site, place a **Temporary Matching Pin** across the 2 braids.

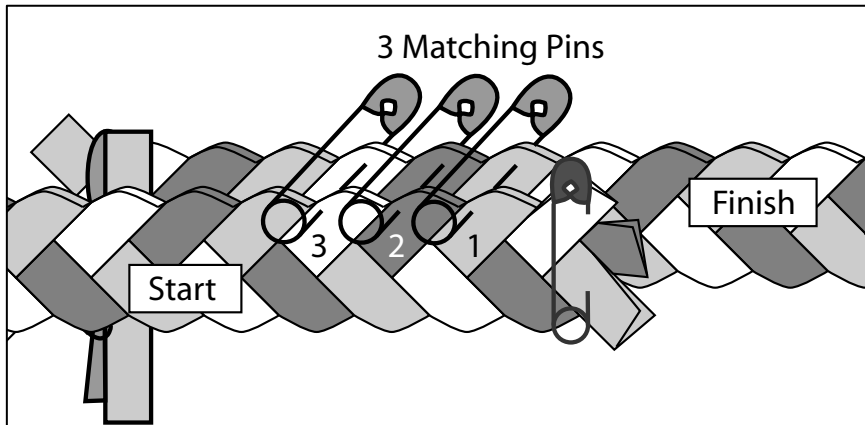

2. Remove the Temp. Matching Pin and place **3 Matching Pins**. As you stab through the front Start braid loops, place the pins far off to the left of each loop. On the back Finish braid, it doesn't matter where you place the pin.

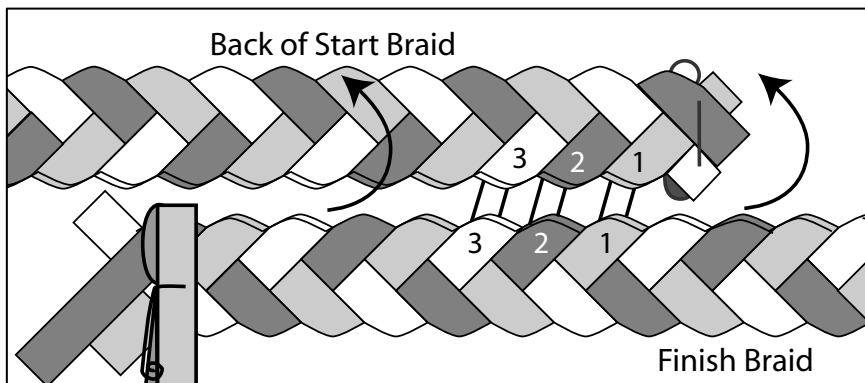

3. Reflect the front Start braid upward, so that you can see the loops of the Finish Braid (1, 2, 3).

Notice that you can see the three Matching Pins between the braids.

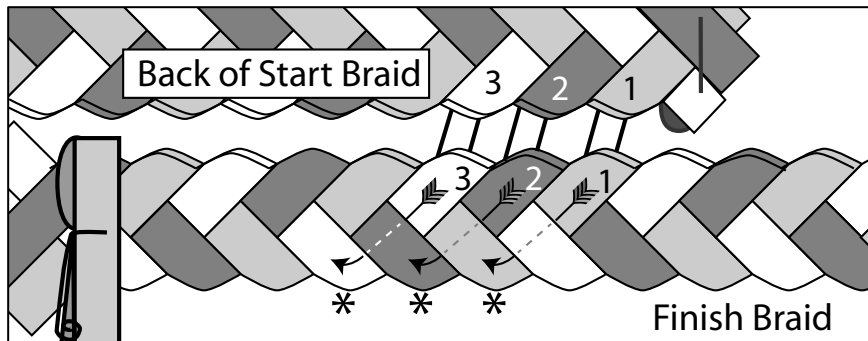

4. Focus on the Finish Braid. You need to identify the 3 loops down and to the left of the pinned loops. See the asterisked loops.

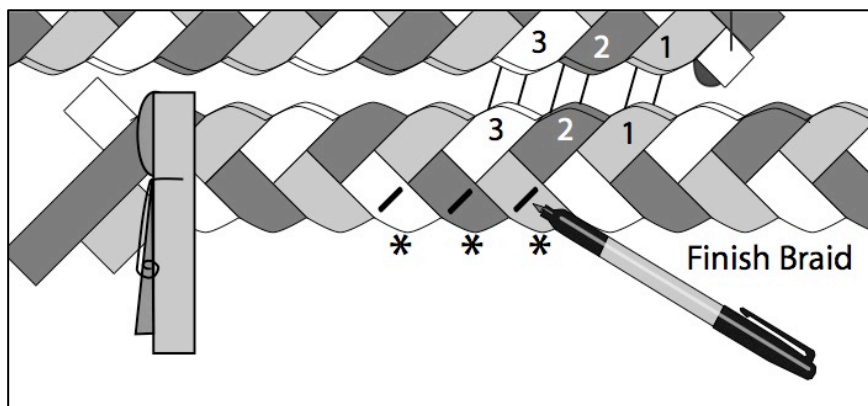

5. Use a marker to draw lines where you will cut the Finish loops later. These lines are drawn as if a line along the edge of the loops above extended downward– see diagram.

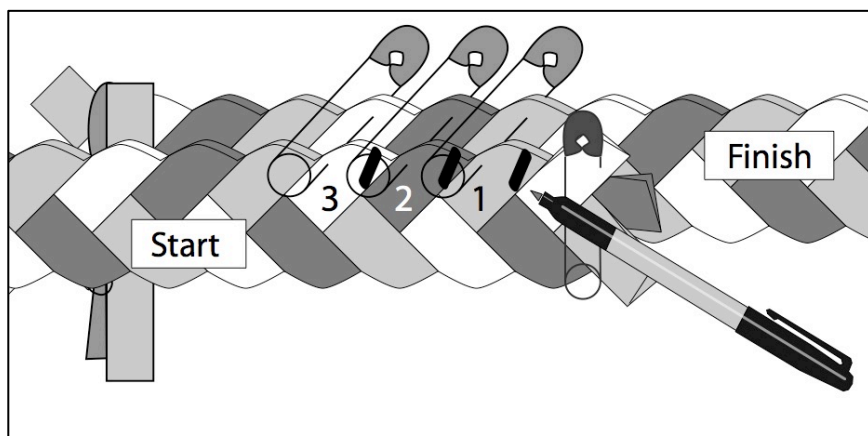

6. Reflect the Start braid back downward in front of the Finish braid.

Use the marker to make lines far off to the right of each pinned Start loop. Move the Safety Pins out of the way as needed.

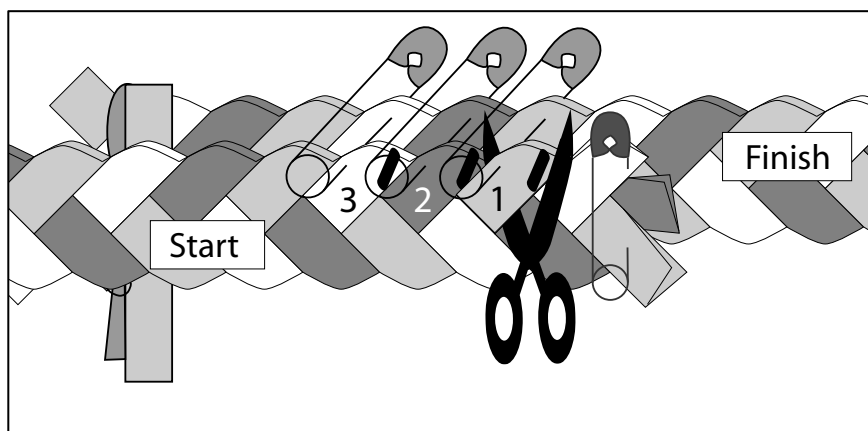

7. Being careful to avoid the safety pins, cut the Start Loops on the marker lines.

Cut loop 1, then loop 2, then loop 3.

(Do not cut the Finish loops yet).

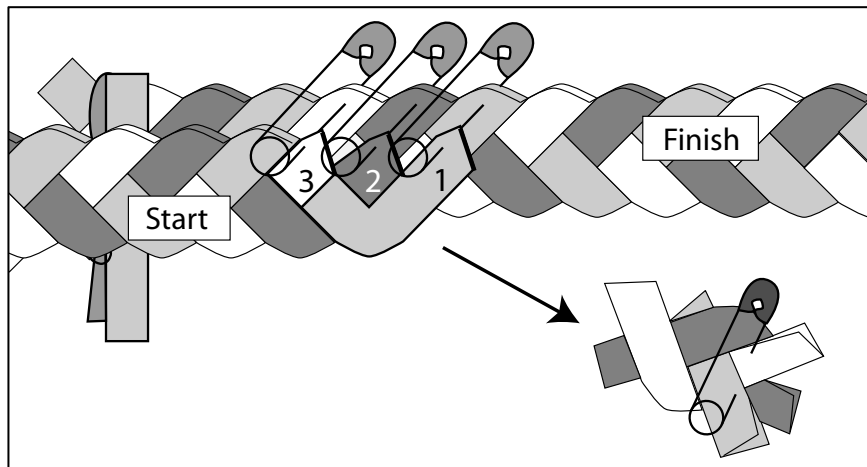

8. After cutting, the Start loops should pull away cleanly from the braid.

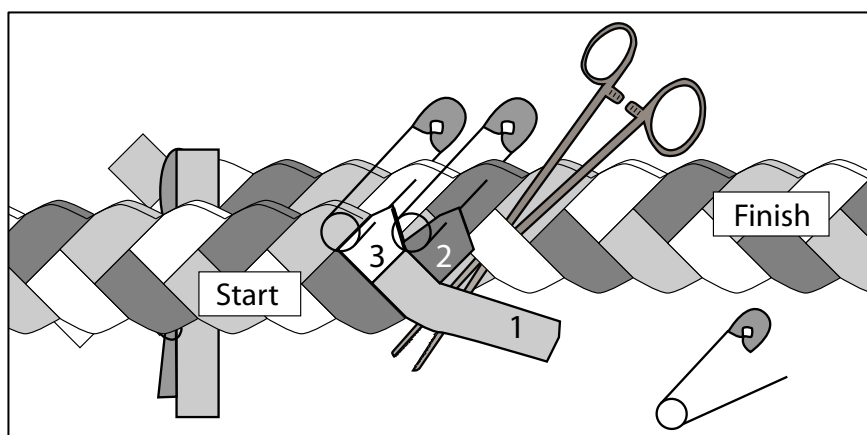

9. Remove the Matching Pin from the #1 set of strands.

Place a hemostat down the path of the Finish braid's loop #1, as shown.

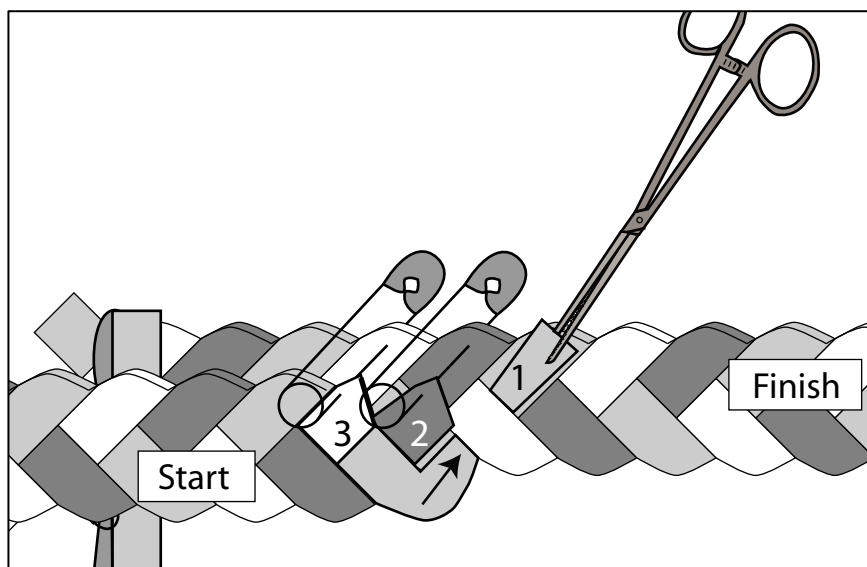

10. Place the cut end of Start loop #1 in the teeth of the hemostat, and pull it upward along the path of Finish Loop #1.

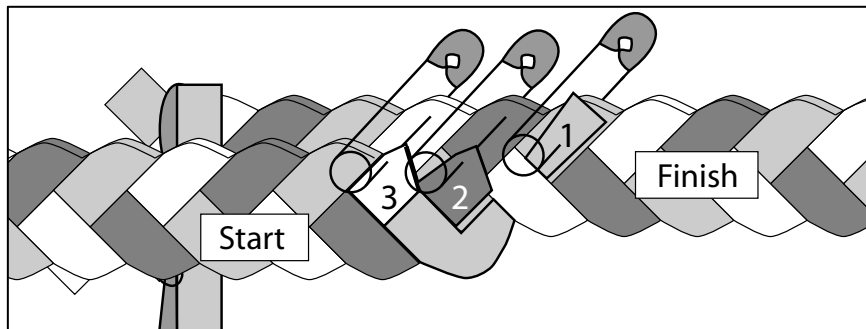

11. Use the Matching Loop Pin (which you removed in Step #9) to re-pin the #1 set of loops together again.

Note: no further loops are re-woven.

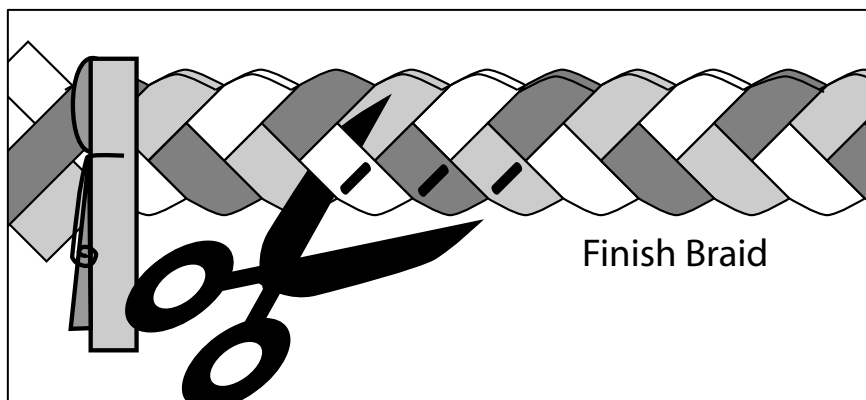

12. Reflect the Start braid off to the right so that you can see the Finish braid. (Note: for clarity, only the Finish braid is shown).

Cut the Finish loops, working from left to right.

** The right-most loop is partly hidden by the rewoven Start strand. Cut it carefully at the marker line.

13. At this point you can sew the strands together in any order, since all weaving of strands is complete. Each set you sew together will consist of:

- pulling on strands to get some length,
- placing them right sides together,
- rotating the right strand 90 degrees for sewing a diagonal seam,
- trimming the seam, re-folding the strand, and
- working the strand back into the braid...

before starting over with the next set of strands.

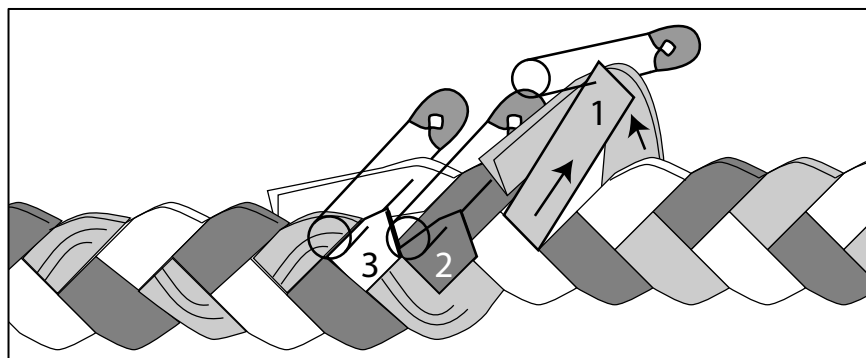

14. Pull on both ends of a set to get some length to work with. Keep the strands pinned while you are pulling.

You will have to pull the hardest on the Start strand, which is why the braid on the left has a lot of wrinkled loops.

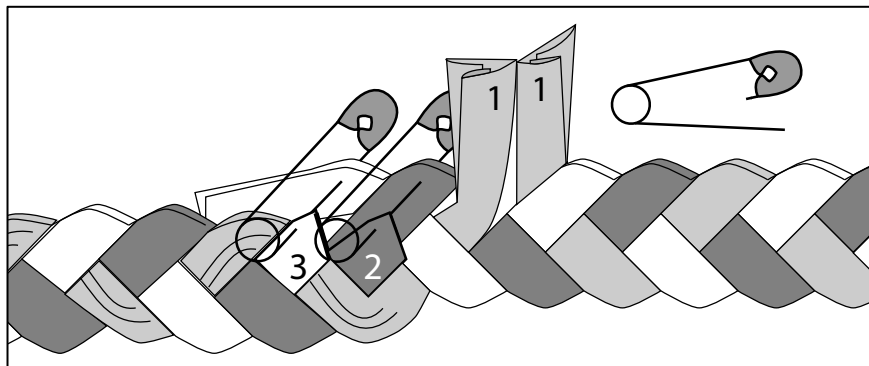

15. Remove the matching pin and line the ends up so that they are even, as shown.

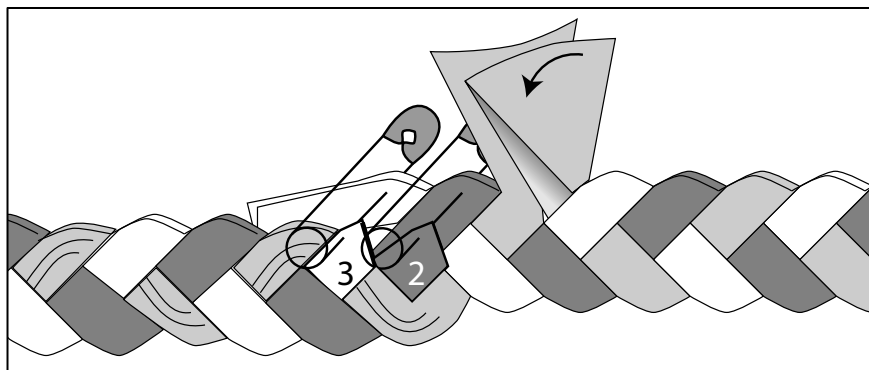

16. Open out the folds of each strand. Turn the strand on the right 90 degrees to the left.

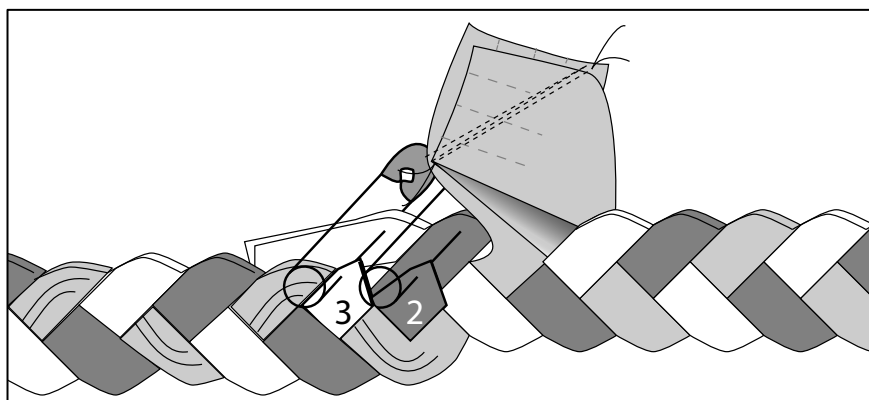

17. The corners have been lined up, and a seam triple-sewn from corner to corner.

Trim off the triangular allowances, leaving about 1/8" of fabric.

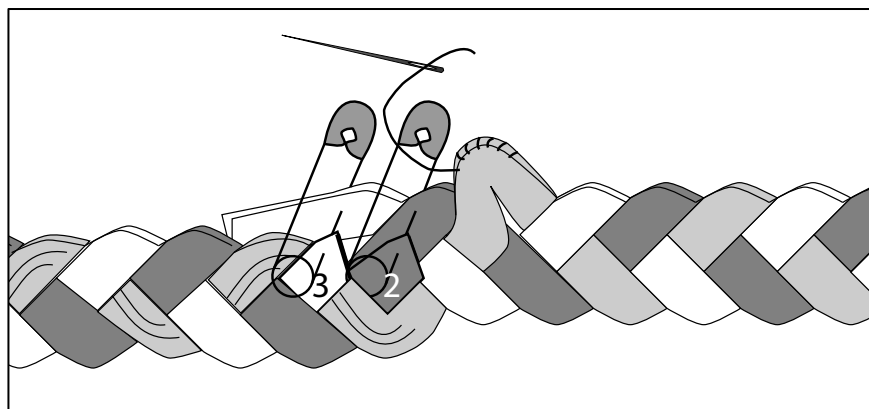

18. Re-fold the strand as for braiding.

Optional: stitch the folds closed over the seamed area.

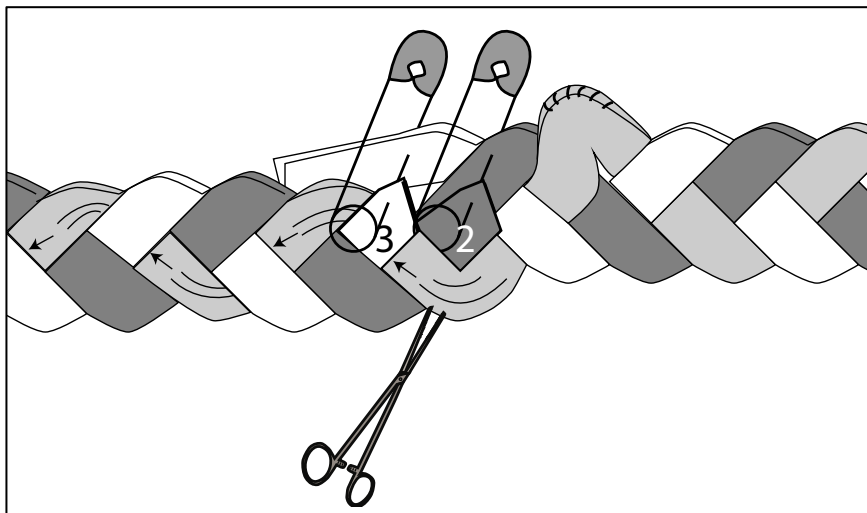

19. Use hemostats to “restore” the braid, which means working the strand back into the braid.

Most of the length was pulled from the left, Start side, so that is where most of the excess will be eased back in.

20. Repeat the process laid out in steps 14 – 19 for the two remaining sets of strands.

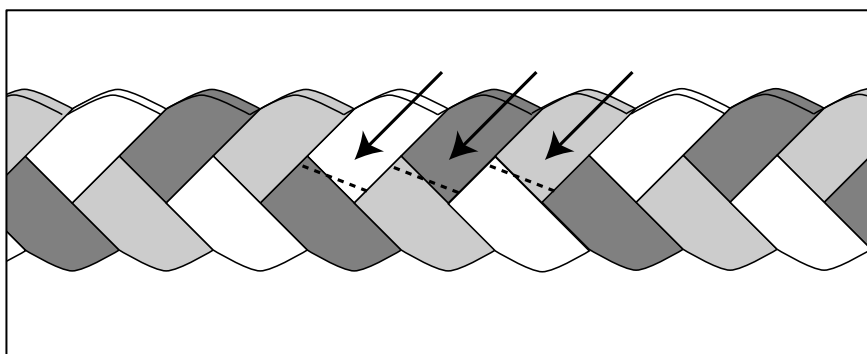

21. When your braid is butted, where are your seams hidden?

They should be mostly buried beneath over-lying loops, and not visible on the back of the braid.